

GE
Security

Fiber Optic System
Digital Video and Audio
Models B741AV and B7741AV

installation instructions

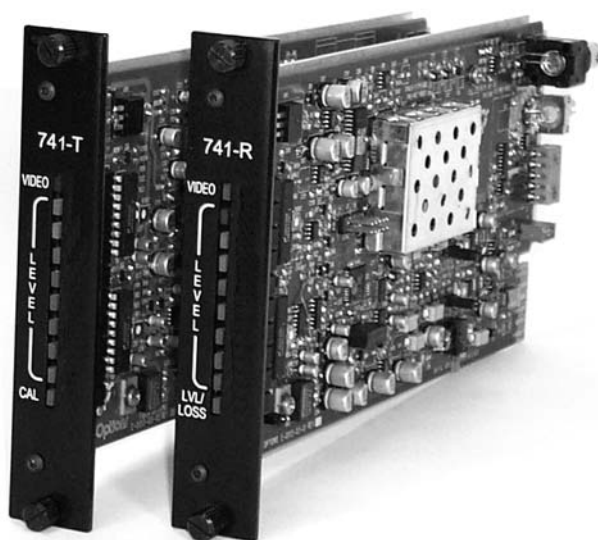

imagination at work

GENERAL

This manual is a guide to the installation and operation of the B741AV and B7741AV series fiber optic video and single-channel audio transmission systems. Please read the entire manual before installing the equipment.

NOTE: The series numbers B741AV, B741AVT and B741AVR will be used to describe all models of transmitters and receivers unless noted otherwise.

The B741AV system offers transmission of one-way 10-bit digital video and one channel of broadcast-quality audio over one multimode fiber. The B7741AV system uses one single-mode fiber. A complete system consists of a transmitter and a receiver.

Units are designed for standalone operation in a 501R enclosure or for installation in Fiber Options' 503H, 515R1 or 517R1 Card Cages.

Unpacking the Unit

In the event that anything is missing from the following list, contact your authorized Fiber Options dealer or representative.

B741AVT Transmitter or B741AVR Receiver

Instruction manual

Save the original packing materials in case it becomes necessary to return the unit.

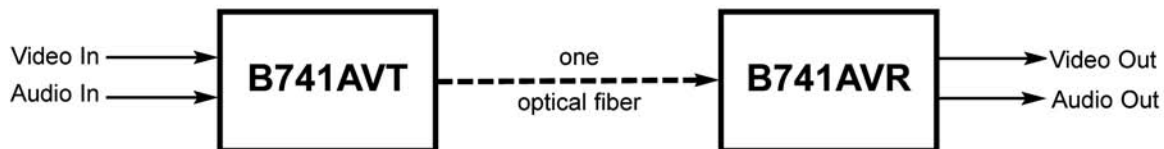
SYSTEM DIAGRAM**INSTALLATION****Installation Considerations**

This fiber-optic link is supplied as a rack card. The rack card can be used in the standalone configuration if placed in a 501R enclosure. Units should be installed in dry locations protected from extremes of temperature and humidity.

Perform the following to install the unit after performing the MODULE SETUP procedures.

Standalone Modules (Rack Card in 501R)

1. Determine where the module is to be installed, and ensure that there is adequate space for making the various cable connections and for reading the diagnostic LEDs.

2. Standalone modules can be attached to suitable flat surfaces with four no. 6 (3-mm) screws. Once the plate is securely attached to a flat surface, the cable connections can be made. The type of screws chosen must be suitable for the surface on which the module is to be mounted.

Rack Cards

Rack cards are designed to be installed in one of Fiber Options' 19-inch (483-mm) EIA standard card-cage racks, either the 503H, 515R1 or the 517R1. They may also be mounted in the 501R standalone rack-card enclosures. Follow these steps to install the card:

515R1 and 517R1 Card Cage Racks

CAUTION: Although rack cards are hot-swappable and may be installed without turning off power to the rack, Fiber Options recommends that the power switch on the rack power supply be turned OFF and that the rack power supply is disconnected from any power source.

1. Make sure that the card is oriented right-side up, and slide it into the card guides in the rack until the edge connector at the back of the card seats in the corresponding slot in the rack's connector panel. Seating may require thumb pressure on the top and bottom of the card's front panel.

CAUTION: Take care not to press on any of the LEDs.

2. Tighten the two thumb screws on the card until the front panel of the card is seated against the front of the rack.

501R Standalone Enclosures

CAUTION: The rack card module can ONLY be powered by 13.5-16 VDC. AC power must not be used. Fiber Options recommends the use of the 613P power adapter.

CAUTION: Fiber Options recommends that the enclosure is not connected to any power source during installation.

1. Look inside the enclosure to determine the location of the socket for the edge connector on the card. Orient the card so that it will seat in the socket, and slide it into the enclosure until the edge connector at the back of the card seats in the socket. Seating may require thumb pressure on the ends of the card's front panel.

CAUTION: Take care not to press on any of the LEDs.

2. Tighten the two thumb screws on the card until the front panel of the card is seated against the front of the enclosure.

MODULE SETUP

Prior to installing the units, the alarm, audio level, and input impedance jumpers and the optical display selector switch need to be setup for proper system operation.

Audio Level

The B741AV system features dual audio level operation to meet the system requirements of -10 dB audio reference and

0 dB/+4 dB audio reference level. All units are shipped from the factory with the audio level jumper set to 18 dB (0 dB audio reference level). At this setting, the 18 dB of operating range will support maximum audio levels of +18 dB.

If a low audio input level causes the audio display to remain dark, the input sensitivity of the B722A can be increased by switching to the 8 dBu maximum scale. Jumpers W5 and W7 on the transmitter and jumper W2 on the receiver select this function. See Figures 1 and 2.

For systems running at -10 dB, typical for VCRs and DVD players, the jumpers should be set to the 8 dB position.

The user has the added option of setting the transmitter input to 8 dBu and the receiver output to 18 dBu. This will add 10 dB of gain to the system, but will also increase system Signal-To-Noise Ratio (SNR).

Input Impedance

The B722A is shipped with the input impedance set at high impedance (high-Z). To select a 600-ohm input impedance in place of the high-Z input, move jumper W6 on the transmitter. See Figure 1.

Alarm Jumper

Rack cards are supplied with an alarm function that activates if the optical signal input to the receiver fails. The alarm is always indicated on the front panel of the card by a red LEVEL/LOSS™ LED. The alarm may also be output to the rack power supply, where a sonalert (audible alarm) and alarm output contact closure may be activated.

The alarm is set to ON (pins 2-3) at the factory. If the alarm output is not desired, move jumper W4 on each receiver card to the DISABLE position (pins 1-2). Refer to Figure 2.

NOTE: Disabling the alarm does not affect the operation of the LEVEL/LOSS™ LED. Loss of optical signal will always be indicated by a red LEVEL/LOSS™ LED.

Optical Display Selection

The receiver provides two alternative methods of displaying the strength of the optical signal. At the bottom of the LED display column is an LED labeled LVL/LOSS.

FIGURE 1: B741AVT TRANSMITTER JUMPERS

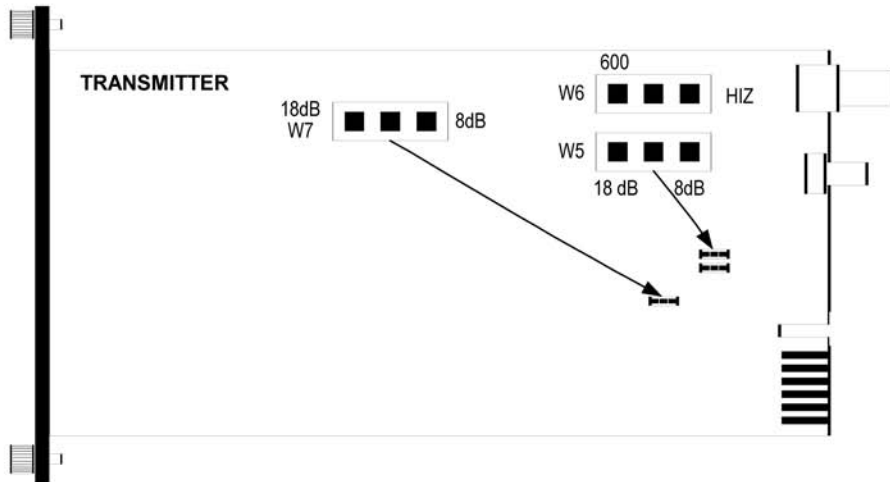

Jumper	Function
W5	Audio Input Level
W6	Input Impedance
W7	Audio Input Level

FIGURE 2: B741AVR RECEIVER JUMPERS

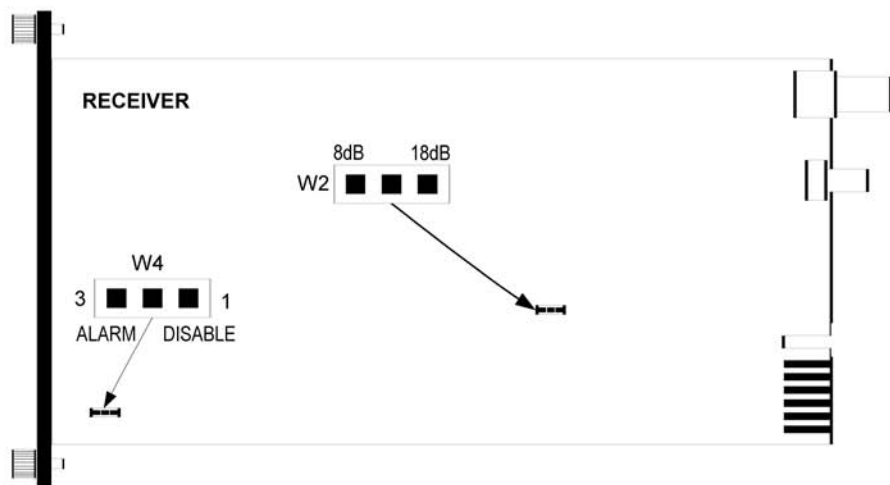

Jumper	Function
W2	Audio Output Level
W4	Alarm Enable/Disable

This is Fiber Options' patented LEVEL/LOSS™ display that indicates the condition of the optical signal; details of its operation may be found in the LED OPERATION section on page 7.

On the B741AVR, an alternative optical signal strength display has been incorporated. This consists of the LED bar graph display labeled LEVEL in the LED column. The LVL/LOSS LED indicates signal strength by glowing either green or red. The bar graph displays signal strength by the number of illuminated LEDs in the eight-segment bar graph.

The factory default function for the LEVEL LEDs is to display audio levels with the Optical Display Select switch set to the left position. Optical signal strength is displayed on the LVL/LOSS LED. However, the LEVEL bar graph display can be used to display optical strength. To select the optical bar graph display, find the Optical Display Selector switch on the rear panel of the receiver. Refer to Figure 4. Set the switch to the right position to activate the optical signal strength display.

CONNECTIONS

Video Connections

Connect the video source cable to the input BNC jack on the transmitter. Connect monitor equipment to the output BNC jack on the receiver.

Fiber Options suggests that Belden number 9259 or equivalent coaxial cable should be used.

Fiber Optic Cable Connection

Most cable manufacturers identify the individual fibers in the cable. Select appropriately terminated fiber and mark both ends with unique identification label (e.g. for cable no. 03, fiber no. 08) to ensure that the fiber connected to the near end is the same one that is connected to the far end. The proper optical connection will link the transmitter's OUT port to the receiver's IN port. See Figures 3 and 4.

1. Wipe the inside of the port's sleeve with a lint-free pipe cleaner moistened with reagent-grade isopropyl alcohol. Blow dry with dry air.
2. Clean the connector using a lint-free cloth dampened with alcohol to thoroughly wipe the side and end of the ferrule. Blow the ferrule dry with dry air. Visually inspect the ferrule for lint.

3. Fasten the fiber optic cable to the port.

Audio Cable Connection

Audio input and output signals are connected to detachable 5-pin screw terminal connectors located on the rear of the modules. Refer to Figures 3 and 4.

Audio connection options include:

<u>Transmitter</u>	<u>Receiver</u>
Balanced input	Balanced output
Balanced input	Unbalanced output
Unbalanced input	Unbalanced output
Unbalanced input	Balanced output

NOTE: Signal strength remains the same regardless of type of connection.

For a balanced connection, connect the external equipment to the (+) and (-) pins. For an unbalanced connection, add a short jumper between the (-) pin and the G (ground) pin.

Test Connections

The transmitter is provided with two test output screw terminal connectors as shown in Figure 3. Connection to these is described in TEST MODE on page 6.

Power Connections

Standalone Modules

CAUTION: Pin 3 on some 501R enclosures is labeled +12 - 16 VDC. The lowest operating voltage for these units is 13.5 VDC. Disregard the labeling for pin 3 on the 501R enclosure.

Standalone modules consist of a rack card housed in a 501R enclosure. Rack modules can only be powered with 13.5 -16 VDC. 501R enclosures are supplied with a detachable screw terminal connector for power. Make the power connections according to the label on the enclosure.

Rack Modules in 503H, 515R1 or 517R1 Racks

Rack modules are automatically connected to the rack power bus when inserted into the card cage. Power is applied to the modules when the power switch on the rack power supply is switched ON.

NOTE: To provide earth ground reference, Stand Alone (Enclosure) modules need to be connected to a good earth ground. This can be accomplished by connecting a copper-based conductor from the modules DC Common/Ground pin to an approved earth ground.

FIGURE 3: B741AVT TRANSMITTER REAR VIEW

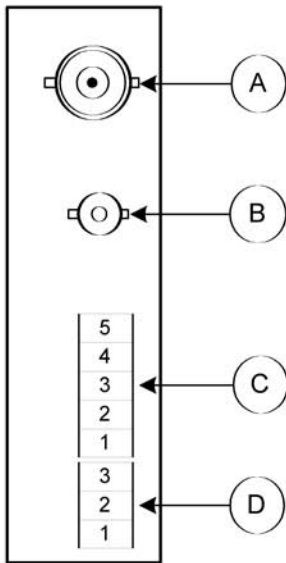

Legend

Item	Description
A	Video Connector
B	Optical (Fiber) Connector
C	Audio Connector
D	Test Output Connector

Audio Connections (C)

Pin	Function
5 (L+)	Audio +
4 (L-)	Audio -
3 (G)	Ground
2 (R+)	Not Used
1 (R-)	Not used

Test Connections (D)

Pin	Function
3 (E)	Ground
2 (+)	Audio +
1 (-)	Audio -

FIGURE 4: B741AVR RECEIVER REAR VIEW

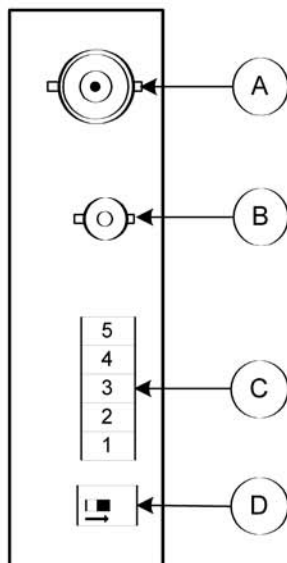

Legend

Item	Description
A	Video Connector
B	Optical (Fiber) Connector
C	Audio Connector
D	Optical Display Select Switch

Audio Connections (C)

Pin	Function
5 (L+)	Audio +
4 (L-)	Audio -
3 (G)	Ground
2 (R+)	Not Used
1 (R-)	Not used

Optical Display Select Switch (D)

Position	Function
Left	Normal LEVEL/LOSS LED display
Right	Enhanced LEVEL/LOSS LED display

SMARTS™ DIAGNOSTICS

The B741AV is equipped with an extensive built-in Status Monitoring And Reliability Test System (*SMARTS™*) diagnostics capabilities based on the arrays of LEDs on the front panel of each module.

LED Operation

Refer to Table 1 for an explanation of how to diagnose system faults using the LEDs built into the Fiber Options units.

The B741AV transmitter has a vertical LED display that represents the audio channel. See Figure 3.

The receiver also has a vertical LED display, similar to the transmitter. The primary difference is that the CAL LED is not present in the receiver. An optical signal strength LVL/LOSS (LEVEL/LOSS™) LED has been added. See Figure 4.

Video Indicator

This LED glows green if the unit sees an adequate video sync signal. It will be green if the scene is completely dark or if the lens is covered, as long as the camera is functioning correctly.

Consequently, a dark monitor does not indicate a lack of video signal.

LEVEL Indicator

This bar-graph arrangement of LEDs works as a dynamic audio level indicator. Each LED segment represents approximately 2 dB of signal strength. As with audio level indicators on other audio equipment, if the display is constantly in the red, the audio level is excessive and will experience clipping. This must be corrected on the audio equipment.

The LEVEL column on the receiver may be used to display the optical signal strength. Refer to OPTICAL DISPLAY SELECTION on page 2 for instructions on how to select this function. If selected, the optical signal will be displayed on the eight-segment LED display. The more LEDs that are illuminated, the stronger the optical signal.

LVL/LOSS Indicator

The LEVEL/LOSS™ LED on the receiver indicates that the received optical signal is adequate (green) or inadequate (red). In the optical signal strength mode, which displays optical strength with the bar graph, the LEVEL/LOSS™ LED flashes.

CAL Indicator

The CAL LED on the transmitter provide two functions. Under normal operation, this LED glow green, indicating that there is power to the unit.

If the unit is in the TEST mode, as described below, this LED glows amber.

The TEST Mode

The TEST mode verifies that the audio channels are functioning correctly without having to connect any audio equipment to the fiber optic units. To carry out this test

1. Create a jumper set as shown in Figure 6. The calibration test signal level is 0 dB.
2. Set the jumpers W6 to the HI Z position.
3. Connect the jumper set between the AUDIO connector and the CALIBRATE connector on the rear panel of the transmitter.
4. Power up the unit and observe the following:
 - a. The CAL LED should glow amber, and
 - b. If the AUDIO INPUT LEVEL jumpers are set for the 18 dB maximum, the bottom LEVEL LED should glow green.
 - c. If the AUDIO INPUT LEVEL jumpers are set at 8 dB max, then the middle segment of the LED bar graph should be illuminated. This indicates correct functioning of the unit.
5. Remove power from the unit and remove jumpers.
6. Set W6 to the correct position for normal operation.
7. Power up the unit.

Special Setup Procedures

CAUTION: Take all normal precautions to protect the unit from static electricity during the following procedures.

The B741AV is shipped with the maximum input/output levels set at 18 dBu and the the input impedance set at high-Z.

To select a 600-ohm input impedance in place of the high-Z input, move jumpers W6 on the transmitter. See Figure 1.

FIGURE 6: TRANSMITTER TEST CONNECTIONS

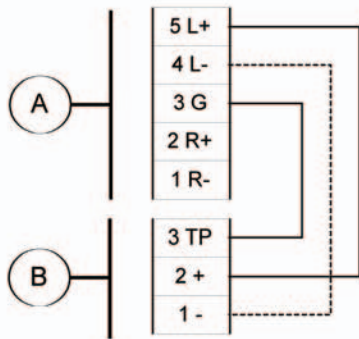

Transmitter Legend

Item	Function
A	Audio Connector
B	Test Output Connector

Audio Connections

Pin	Function
5 (L+)	Audio +
4 (L-)	Audio -
3 (G)	Ground
2 (R+)	Not Used
1 (R-)	Not Used

Test Connections

Pin	Function
3 (TP)	Ground
2 (+)	Audio +
1 (-)	Audio -

If a low audio input level causes the audio display to remain dark, the input sensitivity of the B741AV can be increased by switching to the 8 dBu maximum scale.

Jumpers W5, and W7 on the transmitter and jumper and W2 on the receiver select this function. See Figures 1 and 2.

The user has the added option of setting the transmitter input to 8 dBu and the receiver output to 18 dBu. This will add 10 dB of gain to the system, but will also increase system Signal-To-Noise Ratio (SNR).

OPERATION

To operate the B741AV rack-mount system, connect the rack power supply to an AC outlet and set the power switch to ON.

Refer to TEST MODE on page 7 for instructions on how to execute the test mode.

For an explanation of LED color codes, refer to LED OPERATION on page 7.

MAINTENANCE

There is no operator maintenance other than keeping the units clean.

CONTACTING FIBER OPTIONS

If you cannot determine the cause of your problem and you are in the U.S. or Canada, call the Fiber Options Headquarters. If you are outside the U.S. or Canada, call the closest international office as listed on the back page of this manual.

Have the following information available: exact model number and product code of your fiber-optic links, and a listing of the diagnostic indicators and their respective color/condition.

SHIPPING AND PACKAGING

Before shipping or transporting your Fiber Options unit, pack it securely to prevent damage that could occur in transit. Use care to protect all connectors, LEDs, and corners from possible damage.

RETURNS TO FIBER OPTIONS

If any equipment must be returned to Fiber Options for repair or replacement, you must obtain authorization from our Return Authorization department before shipping.

Customer Support

For assistance in installing, operating, maintaining, and troubleshooting this product, refer to this document and any other documentation provided. If you still have questions, please contact technical support during normal business hours (Monday through Friday, excluding holidays, between 6 a.m. and 5 p.m. Pacific Time).

GE Security

Call: 888 437-3287 (US, including Alaska and Hawaii; Puerto Rico; Canada)

Outside the toll-free area: 503 885-5700

Fax: 561 998-6224

www.gesecurity.com



GE Security

www.GESecurity.com

U.S.

T (561) 998-6100

T 888-GE-SECURITY
888 (437-3287)

F 561 998-6224

E gesecuritycustserv@ge.com

Asia

T 852-2907-8108

F 852-2142-5063

Australia

T 613-9239-1200

F 613-9239-1299

Canada

T 519-376-2430

F 519-376-7258

Europe

T 44-113-238-1668

F 44-113-253-8121

Latin America

T 305-593-4301

F 305-593-4300