

# EH4010/EH4014 Enclosure

## INDOOR, MEDIUM

### Product Features

- Low Cost
- Indoor Applications
- Contemporary Design
- Medium Sizes
- For Use with Fixed Mount or Pan/Tilt
- Easy Access for Service and Installation
- For Use with Medium-to-Large Format Cameras
- Upright or Inverted Applications



EH4014

The **EH4000 Series** are low cost camera enclosures designed especially for indoor applications.

The enclosure features a removable rear cap for easy access to camera sled. Adjustable glands on the rear cap allow for easy installation of the power and video cables, and a removable front cap allows the installer to manually adjust the lens without removing the camera.

The **EH4010** can be used with medium format cameras and the **EH4014** can be used with medium-to-large format cameras. The **EH4014** will accommodate fixed focal length lenses or motorized zoom lenses (with or without auto iris).

These enclosures can be used in fixed mount applications or mounted to a light duty pan/tilt, such as our PT270-24P or PT280-24P. They can also be used with our PS20 Series scanner (when used indoors).

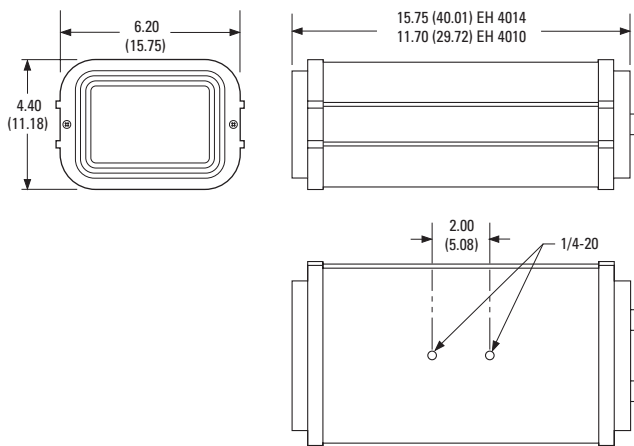

NOTE: VALUES IN PARENTHESES ARE CENTIMETERS;  
ALL OTHERS ARE INCHES.

EH4010/EH4014 DIMENSION DRAWING



# TECHNICAL SPECIFICATIONS

## MODELS

|        |  |
|--------|--|
| EH4010 | Extruded aluminum enclosure, 11.70-inch (29.71 cm) body length |
| EH4014 | Extruded aluminum enclosure, 15.75-inch (40.01 cm) body length |

## MECHANICAL

|                              |   |
|------------------------------|---|
| Camera Mounting<br>EH4010    | Adjustable L-shaped bracket with one mounting hole attached to the slide-out rail |
| EH4014                       | Multiple holes on removable camera sled   |
| Maximum Camera and Lens Size | Accepts camera and lens combinations* (including BNC connector) up to:            |
| EH4010                       | 3.50" H x 5.25" W x 8.00" L (8.89 x 13.33 x 20.32 cm)                             |
| EH4014                       | 3.50" H x 5.25" W x 12.00" L (8.89 x 13.33 x 30.48 cm)                            |
| Viewing Window               | 0.125" (3.17 mm) thick Lexan®   |
| Viewing Window Area          | 2.50" H x 3.75" W (6.35 x 9.52 cm)  |
| Cable Entry                  | Two compression glands on rear cap; maximum 5/16" (0.79 cm) cable diameter        |

\*Assumes lens is fully extended.

## GENERAL

|                 |   |
|-----------------|---|
| Construction    | Extruded aluminum body; injection molded black ABS plastic end caps |
| Finish          | Gray polyester powder coat  |
| Environment     | Indoor only   |
| Unit Weight     |   |
| EH4010          | 3.68 lb (1.67 kg)   |
| EH4014          | 4.98 lb (2.26 kg)   |
| Shipping Weight |   |
| EH4010          | 5 lb (2.26 kg)  |
| EH4014          | 6 lb (2.7 kg)   |

## CERTIFICATIONS

- CE, Class B
- UL Listed

## RECOMMENDED MOUNTS

|                         |                  |  |
|-------------------------|------------------|--|
| <b>Ceiling/Pedestal</b> | EM1009U, EM1015U | Medium duty ceiling/pedestal mount; maximum load 40 lb (18.12 kg)                                |
|                         | EM3000           | Ceiling J-mount; maximum load 40 lb (18.12 kg)   |
|                         | MM22             | Medium duty ceiling/pedestal mount; maximum load 40 lb (18.12 kg)                                |
| <b>Wall</b>             | EM1900U          | Medium duty wall mount; maximum load 40 lb (18.12 kg)  |
|                         | EM2400           | Light duty wall mount; maximum load 20 lb (9.06 kg)  |
|                         | EM22             | Medium duty wall mount; maximum load 40 lb (18.12 kg)  |
| <b>Pipe/Pole</b>        | EM1109           | Medium duty pedestal mount for vertical pipe or pole applications; maximum load 40 lb (18.12 kg) |
|                         | EM2000           | Medium duty mount for vertical pipe or pole applications; maximum load 40 lb (18.12 kg)          |
|                         | EM2200           | Medium duty mount for horizontal pipe or pole applications; maximum load 40 lb (18.12 kg)        |

## RECOMMENDED PAN/TILTS

|             |  |
|-------------|--|
| PT270-24P   | Light duty pan/tilt, 24 VAC; maximum load 15 lb (6.8 kg)                       |
| PT280-24P   | Light duty pan/tilt, 24 VAC, with pre-wired cable; maximum load 15 lb (6.8 kg) |
| PS20 Series | Medium duty scanner, 24/120 VAC; maximum load 35 lb (15.7 kg)                  |



**Pelco, Inc. Worldwide Headquarters:**  
3500 Pelco Way, Clovis, California 93612-5699 USA  
**USA & Canada** Tel: (800) 289-9100 • FAX (800) 289-9150  
**International** Tel: +1 (559) 292-1981 • FAX +1 (559) 348-1120  
[www.pelco.com](http://www.pelco.com)

Pelco and the Pelco logo are registered trademarks of Pelco, Inc.  
Lexan is a registered trademark of the General Electric Company.  
Product specifications and availability subject to change without notice.  
©Copyright 2008, Pelco, Inc. All rights reserved.