

LCD-2

UNIVERSAL LCD MONITOR DESK MOUNT
MULTI-CONFIGURABLE MOUNT

PRODUCT FEATURES

- can be attached as a clamp-on or bolt through mount *with parts provided*
- holds most 10" - 21" LCD monitors
- accommodates monitors with 75 or 100mm VESA standards
- rotates 360° and has adjustable -5° to +30° tilt
- force arm has adjustable 0° to 60° forward tilt
- load capacity 25 lbs.
- silver powder coat finish

PRODUCT SPECIFICATIONS FOR ARCHITECTS & ENGINEERS

The table/desk mount for the LCD display shall be the Video Mount Products (VMP) model LCD-2. The mount shall be constructed primarily of formed steel and shall incorporate nylon filled nuts. The mount shall be a universal style mount capable of mounting to all 10" - 23" LCD monitors that incorporate 75mm and 100mm VESA standard mounting hole patterns and not necessarily be model specific. The mount shall include both 75mm and 100mm mounting plates. The mount shall be capable of being configured as a clamp style or drill through mount with parts provided. The mount must allow for adjustable tilt from -5° to +30° at the head and a 0° - 60° forward tilt. The load capacity shall be 25 lbs

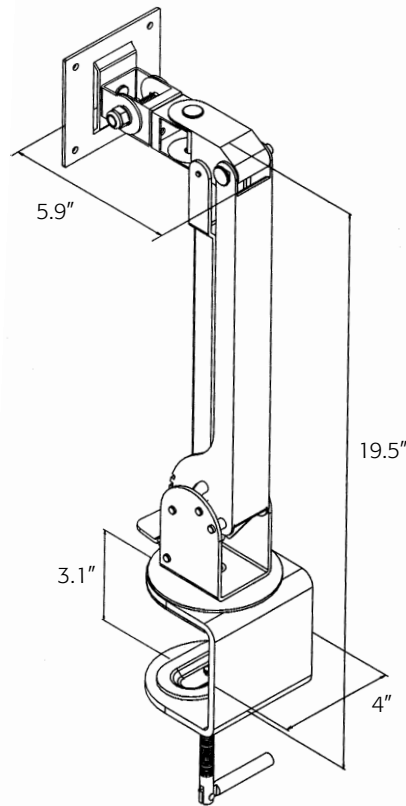

VMP Mounting Systems for
Video, Audio & Security
Video Mount Products

Video Mount Products
325 Log Canoe Circle
Stevensville, Maryland 21666
Phone 410.643.6390 Facsimile 410.643.6615
Website www.videomount.com

MOUNTING SYSTEMS FOR AUDIO, VIDEO & SECURITY