

CASI Data Transmission System
Model S711F2F and S7711F2F

installation instructions

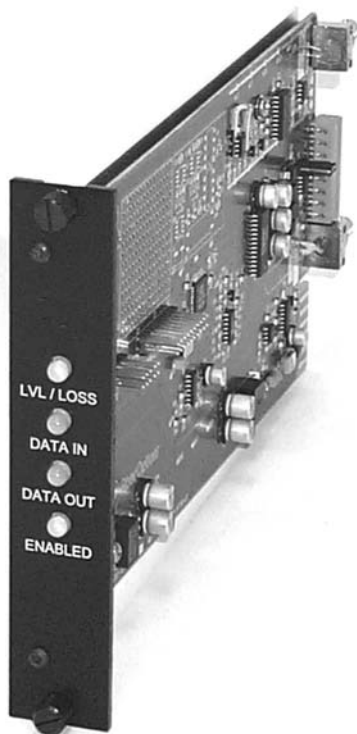

GENERAL

This manual is a guide to the installation and operation of the S711F2F and S7711F2F series fiber optic data transmission systems. Please read the entire manual before installing the equipment.

NOTE: The series numbers S711F2F, S711F2FT and S711F2FR will be used to describe all models of transmitters and receivers unless noted otherwise.

The Series S711F2F and S7711F2F data transmission systems offer simultaneous transmission of duplex digital control data. The S711F2F system operates over one or two multimode fibers while the S7711F2F uses one or two single-mode fibers.

A complete one-fiber system consists of a transmitter, S711F2FT, and a receiver, S711F2FR. A complete two-fiber system consists of two transceivers.

Units are designed for standalone operation or for installation in Fiber Options' 515R1 or 517R1 Card Cages or 501R miniature enclosures.

All S711F2F units have one data input/output connector and one or two fiber connectors.

Unpacking the Unit

In the event that anything is missing from the following list, contact your authorized Fiber Options dealer or representative.

S711F2F Transmitter, Receiver, or Transceiver
(S7711F2F Transmitter, Receiver, or Transceiver)
Instruction manual

Save the original packing materials in case it becomes necessary to return the unit.

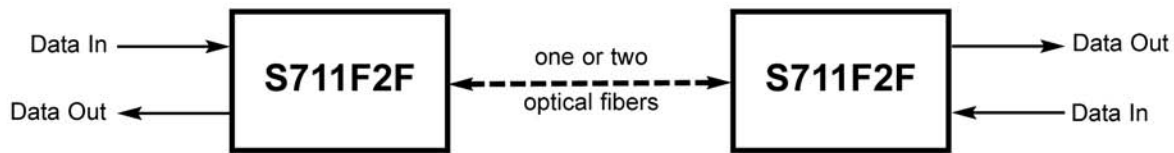
SYSTEM DIAGRAM**INSTALLATION****Installation Considerations**

This fiber-optic link is supplied as a standalone module or as a rack card. Units should be installed in dry locations protected from extremes of temperature and humidity.

Standalone Modules

1. Determine where the module will be installed, and ensure that there is adequate space at both ends for making the various cable connections and for reading the diagnostic LEDs.

2. Standalone modules are provided with mounting holes for four No. 6 screws (3-mm or 3.5-mm). The type of screws must be suitable for the surface where a module will be mounted. See Figure 1.

Rack Cards

Rack cards are designed to be installed in one of Fiber Options' 19-inch (483-mm) EIA standard card-cage racks, either the 515R1 or the 517R1. Follow these guidelines to install rack cards after performing the MODULE SETUP procedures.

515R1 and 517R1 Card Cage Racks

CAUTION: Although rack cards are hot-swappable and may be installed without turning off power to the rack, Fiber Options recommends that the power switch on the rack power supply be turned OFF and that the rack power supply is disconnected from any power source.

1. Make sure that the card is oriented right-side up, and slide it into the card guides in the rack until the edge connector at the back of the card seats in the corresponding slot in the rack's connector panel. Seating may require thumb pressure on the top and bottom of the card's front panel.

CAUTION: Take care not to press on any of the LEDs.

2. Tighten the two thumb screws on the card until the front panel of the card is seated against the front of the rack.

501R Standalone Enclosures

CAUTION: Fiber Options recommends that the enclosure is not connected to any power source during installation.

1. Look inside the enclosure to determine the location of the socket for the edge connector on the card. Orient the card so that it will seat in the socket, and slide it into the enclosure until the edge connector at the back of the card seats in the socket. Seating may require thumb pressure on the ends of the card's front panel.

CAUTION: Take care not to press on any of the LEDs.

2. Tighten the two thumb screws until the front panel of the card is seated against the front of the enclosure.

MODULE SETUP

Alarm Jumper

Rack cards are supplied with an alarm function that activates if the optical signal input to the receiver fails. The alarm is always indicated on the front panel of the card by a red LEVEL/LOSS™ LED. The alarm may also be output to the rack power supply, where a sonalert (audible alarm) and alarm output contact closure may be activated.

The alarm is set to ON (ACTIVE) at the factory with jumper JP4 set to position 2-3. If the alarm output is not desired, move jumper JP4 to the 1-2 position (OFF). See Figure 2.

NOTE: Setting alarm to off does not affect the operation of the LEVEL/LOSS™ LED. Loss of optical signal will always be indicated by a red LEVEL/LOSS™ LED.

CONNECTIONS

Data Connections

Data connections are made to the 8-pin removable screw terminal on the S711F2F according to Table 1. Pin numbering on the module is in descending order from 8 at the top to 1 at the bottom.

When making data connections, always wire the DATA/CONTACT CLOSURE OUT pins on the data equipment to the DATA/CONTACT CLOSURE IN pins on the fiber links, and the DATA/CONTACT CLOSURE IN pins on the data equipment to the DATA/CONTACT CLOSURE OUT pins on the fiber links. See Figures 2 and 3.

Fiber Optic Cable Connection

Most cable manufacturers identify the individual fibers in the cable. Select appropriately terminated fiber and mark both ends with unique identification label (e.g. for cable no. 03, fiber no. 08) to ensure that the fiber connected to the near end is the same one that is connected to the far end.

The proper optical connection will link the transmitter's TRANSMIT (OUT) port to the receiver's RECEIVE (IN) port. See Figure 1.

1. Wipe the inside of the port's sleeve with a lint-free pipe cleaner moistened with reagent-grade isopropyl alcohol. Blow dry with dry air.

2. Clean the connector using a lint-free cloth dampened with alcohol to thoroughly wipe the side and end of the ferrule. Blow the ferrule dry with dry air. Visually inspect the ferrule for lint.

3. Fasten the fiber optic cable to the port.

Power Connections

Standalone Modules

All S711F2F standalone modules are powered by +13.5 - 16 VDC. Connect input power according to the label on the module. Refer to Table 2.

NOTE: To provide earth ground reference, Stand Alone (Enclosure) modules need to be connected to a good earth ground. This can be accomplished by connecting a copper-based conductor from the modules DC Common/Ground pin to an approved earth ground.

FIGURE 1: 501R ENCLOSURE MOUNTING DIMENSIONS

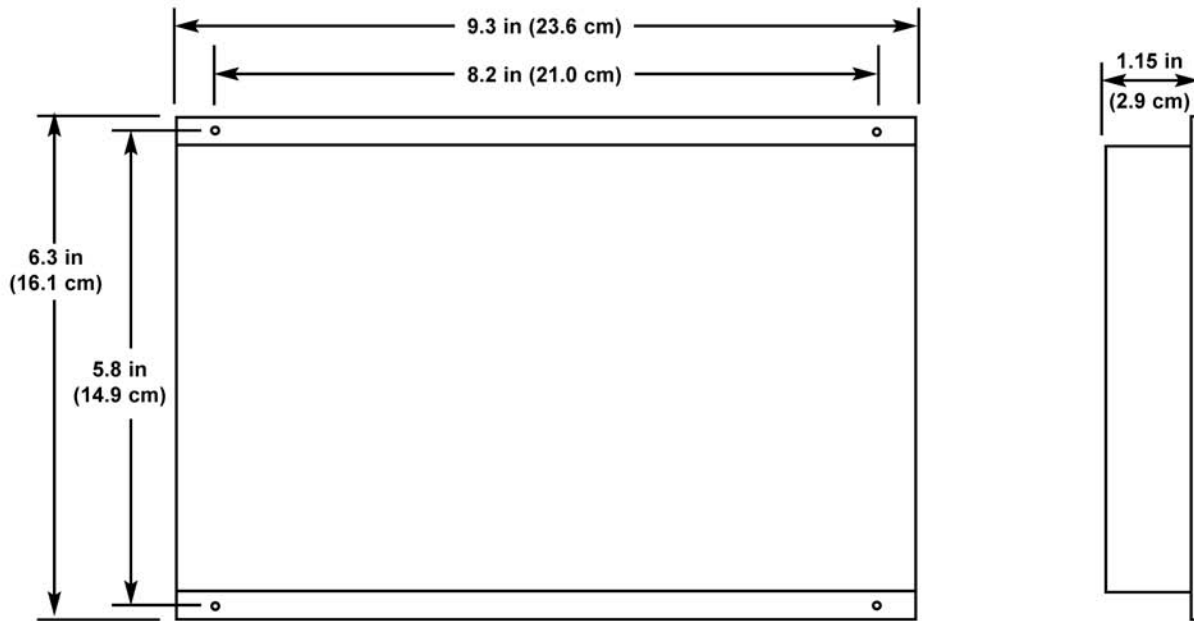

FIGURE 2: RACK-MOUNT TRANSCEIVER

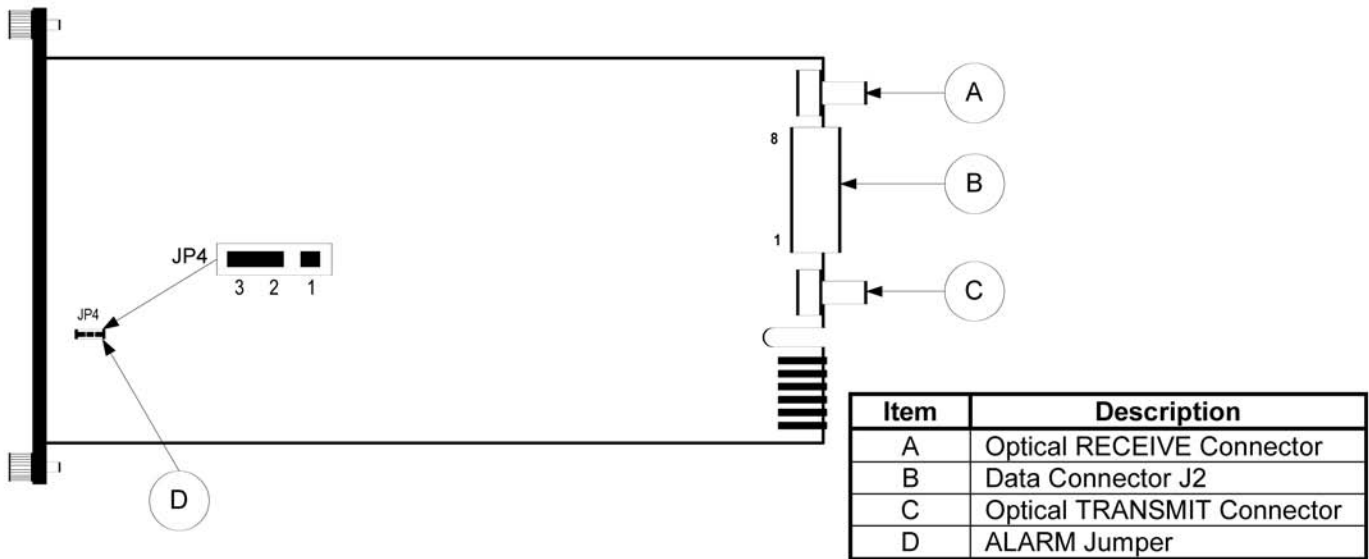

FIGURE 3: FIBER LINK DATA CONNECTIONS

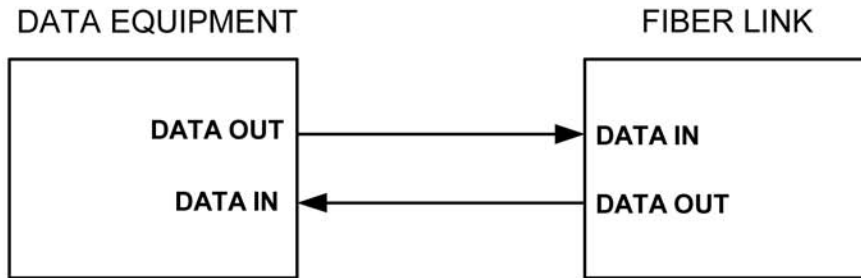

TABLE 1: PIN CONNECTIONS FOR DATA CONNECTOR J2

Pin No.	Function
8	Contact Closure In
7	No Connection
6	Contact Closure Out
5	Contact Closure Out
4	Ground
3	No Connection
2	Ground
1	Data In/Out

TABLE 2: PIN CONNECTIONS FOR POWER CONNECTOR - STANDALONE MODULES

Pin No.	Function
3	13.5 VDC
2	No Connection
1	Ground

Rack Modules

Power connections are made automatically when the card is installed. Refer to Figures 4 and 5 for details on how to connect the S711F2F to external +12 VDC and +48 VDC systems.

To supply power to the rack, connect the rack power supply to an AC outlet and set the power switch to ON.

SMARTS™ DIAGNOSTICS

The S711F2F has built in Status Monitoring And Reliability Test System (SMARTS™) diagnostic capabilities. This includes LED indicators for monitoring data and optical status.

LED Operation

The S711F2F has 4 LED indicators that are very useful in describing the current state of operation, as well as the current status of data flow and fiber optic signal strength. These indicators are LEVEL/LOSS™, DATA I/O, CONTACT IN AND CONTACT OUT.

Table 3 provides a convenient summary of the LED display functions. The LEDs function as follows:

LEVEL/LOSS™ Indicator

This LED is useful for indicating the relative optical signal strength at the fiber optic receiver. When sufficient optical power is being received, the LED is green. If no or insufficient optical power is received, the LED will be red. All data will default to it's failure state level to eliminate bus contention.

DATA I/O Indicator

The Data I/O LED indicates the state of the data being input to and output from the S711F2F over copper. A green DATA I/O LED indicates data is being received over the copper. An amber DATA I/O LED indicates data is being transmitted over the copper. The DATA I/O LED will be off when there is no activity on the copper.

Contact IN Indicator

The CONTACT IN LED indicates the presence of relay/contact closure signal. A green CONTACT IN LED indicates the contact closure input (J2 pin 8) is shorted to ground. An amber LED indicates the contact closure input (J2 pin 8) is not shorted to ground.

FIGURE 4: WIRING DIAGRAM FOR SITES OPERATING AT +12 VDC

Micro/5 and 8RP PCB Site Operating at +12 VDC - Supervised F/2F

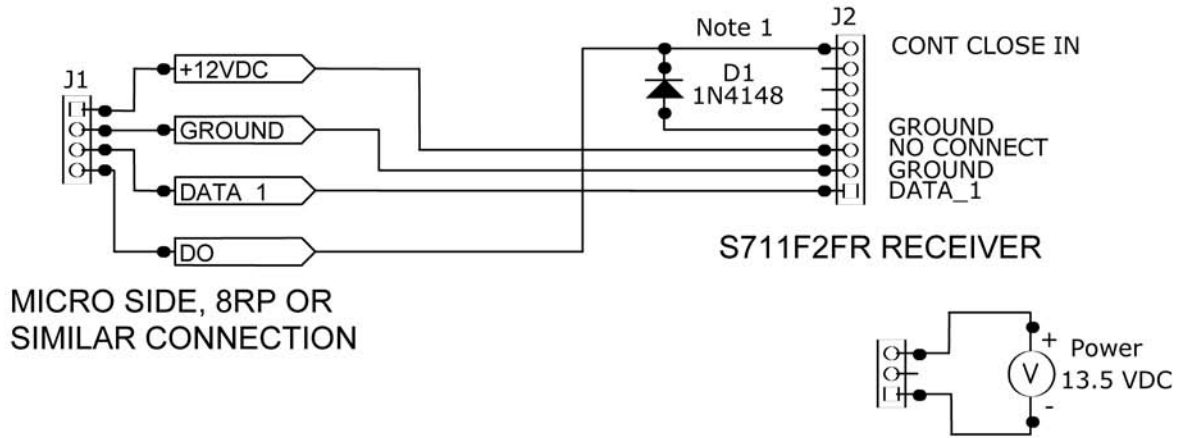

Reader and S711F2F Module Site - Supervised F/2F

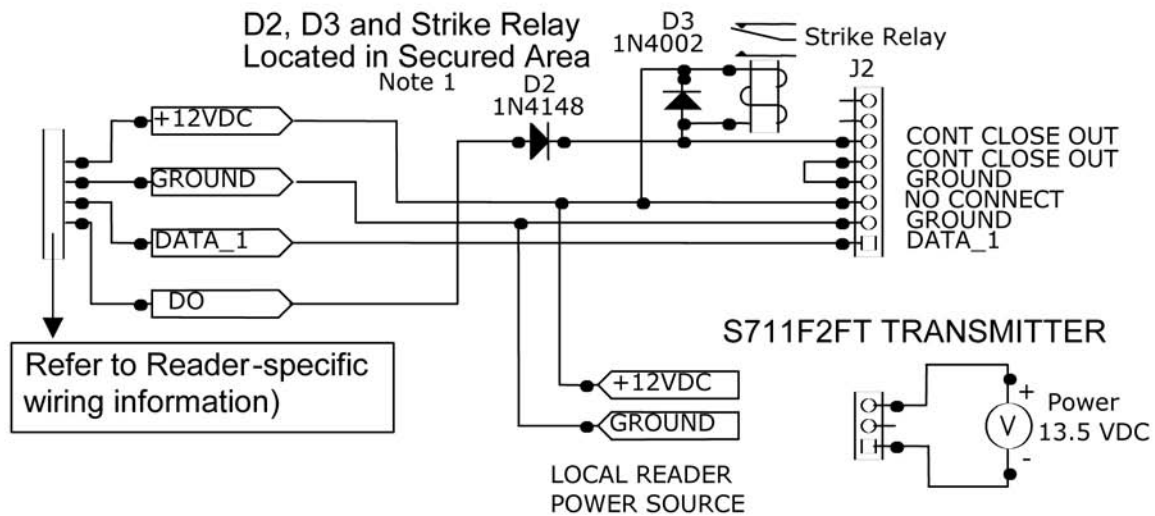

Note 1: Diodes, Strike Relay Components and Power Supplies are provided by Installer.

Transceiver can be S711F2F -RST2 or S711F2F -RST2L; 501R enclosure required per device.

FIGURE 5: WIRING DIAGRAM FOR SITES OPERATING AT +48 VDC

Micro/4 and Micro/2 Site Operating at +48 VDC - Supervised F/2F

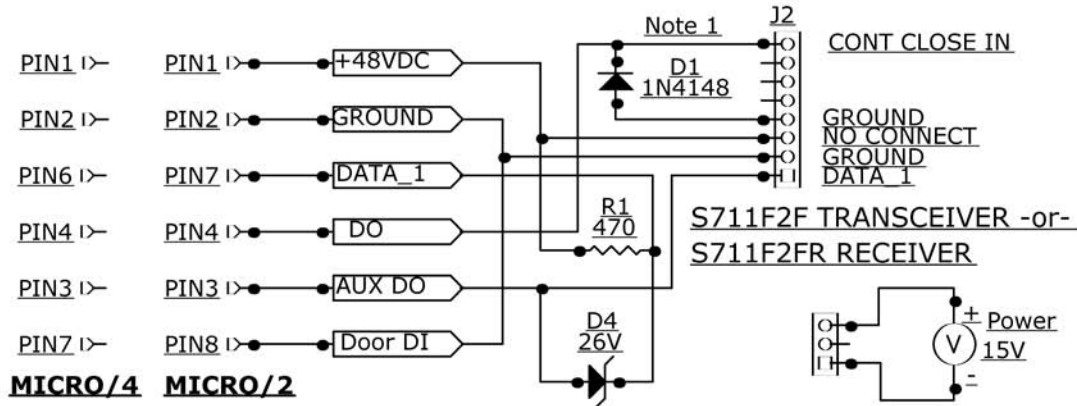

Note: Two 13-V Zener diodes connected in series may be substituted for the 26-V Zener diode.

Reader Site Operating at +48 VDC - Supervised F/2F

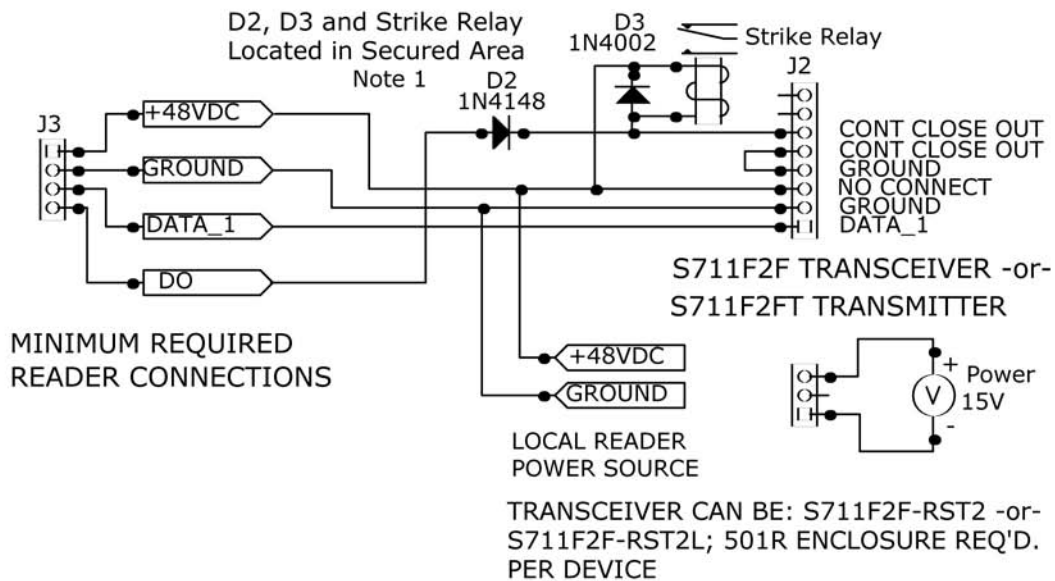

Note: Diodes, Strike Relay Components and Power Supplies are provided by Installer.

CONTACT OUT Indicator

The CONTACT OUT LED indicates the presence of relay/contact closure command. A green CONTACT OUT LED indicates a CLOSED command is received on the fiber. A red LED indicates the an OPEN command is received on the fiber.

This LED will be red when the LEVEL/LOSS™ LED is red and the contacts will open. Whenever the unit is powered down, the contacts will open.

OPERATION

S711F2F links operate automatically once installed. For an explanation of LED color codes, see LED OPERATION and Table 3.

MAINTENANCE

There is no operator maintenance other than keeping the units clean.

TABLE 3: LED DIAGNOSTIC INDICATORS

LED Name	Signal	Color	Indications
LEVEL/ LOSS	Optical	Green	Any shade of green indicates adequate optical signal.
		Red	Optical loss exceeds budget, or no optical signal.
DATA I/O	F2F I/O	Green	Receiving data over fiber (steady or pulsing).
		Amber	Transmitting data over fiber (steady or pulsing).
		Off	No activity on copper at either end.
CONTACT IN	Contact Closure In	Green	Contact closure IN (pin 8) shorted to ground
		Red	Contact closure IN (pin 8) open (not shorted to ground).
CONTACT OUT	Contact Closure Out	Green	Receiving a CLOSED command from the fiber.
		Red	Receiving an OPEN command from the fiber.*

* If the LEVEL/LOSS™ LED is red, the CONTACT OUT LED will be red and the contacts will be open. If the unit is powered down, the contacts open.

Customer Support

For assistance in installing, operating, maintaining, and troubleshooting this product, refer to this document and any other documentation provided. If you still have questions, please contact technical support during normal business hours (Monday through Friday, excluding holidays, between 6 a.m. and 5 p.m. Pacific Time).

GE Security

Call: 888 437-3287 (US, including Alaska and Hawaii; Puerto Rico; Canada)

Outside the toll-free area: 503 885-5700

Fax: 561 998-6224

www.gesecurity.com



GE Security

www.GESecurity.com

U.S.

T (561) 998-6100

T 888-GE-SECURITY
888 (437-3287)

F 561 998-6224

E gesecuritycustserv@ge.com

Asia

T 852-2907-8108

F 852-2142-5063

Australia

T 613-9239-1200

F 613-9239-1299

Canada

T 519-376-2430

F 519-376-7258

Europe

T 44-113-238-1668

F 44-113-253-8121

Latin America

T 305-593-4301

F 305-593-4300